



SECTIONS

Straight and corner sections made of 25mm melamine faced chipboard (MFC) finished with 2mm matching straight ABS impact resistant edges, easy to clean scratch-resistant anti-reflective melamine. 200mm deep countertop and back panel linked at an angle of 90° using provided fittings, 45° pre-mitred edges at the join between the two panels. MFC density 670/730 kgs per cubic meter.

WORKTOPS

Made of 30mm melamine faced chipboard (MFC) finished with 2mm matching straight ABS impact resistant edges, easy to clean scratch-resistant anti-reflective melamine. MFC density 670/730 kgs per cubic meter.

OVERLAY PANELS

Made of 30mm melamine faced chipboard (MFC) finished with 2mm matching straight ABS impact resistant edges. 350mm deep countertop and back panel linked at an angle of 90° using provided fittings, 45° pre-mitred edges at the join between the two panels. MFC density 670/730 kgs per cubic meter.

Melamine finish options:



LACQUERED OVERLAY PANELS

Made of 30mm melamine faced chipboard (MFC) finished with 2mm matching straight ABS impact resistant edges. 350mm deep countertop and back panel linked at an angle of 90° using provided fittings, 45° pre-mitred edges at the join between the two panels. The entire panel surface is coated with matt lacquer. MFC density 670/730 kgs per cubic meter.

Lacquer finish options:



Production lead time: 5 weeks excluding delivery time. Apart from the shown finish options any RAL color can be made to order.

LEATHER COVERED OVERLAY PANELS

Made of 30mm melamine faced chipboard (MFC) finished with 2mm matching straight ABS impact resistant edges. 350mm deep countertop and back panel linked at an angle of 90° using provided fittings, 45° pre-mitred edges at the join between the two panels. The outer surface is covered with abrasion resistant leather finished with decorative matching stitching along the perimeter of the panels. MFC density 670/730 kgs per cubic meter.

Finish options:

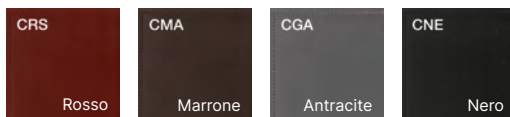

Production lead time: 5 weeks excluding delivery time.

METAL PARTS

Tubular support legs made of 50×50mm 1.5mm steel tube supplied with 3mm steel support plate. All metal parts are epoxy powder coated.

Finish options:



LIGHTING AND ACCESSORIES

Flexible cool white LED strip for overlay panels, 240 Leds 19.2 Watts per meter. You can bend or cut the strip without compromising on functionality. Easy peel-and-stick backing mounts to the lower end of overlay panels. Includes an On/Off switch to fit to the reception back panel, drilling to be carried out on site.

Cool white LED for reception worktops, 240 Leds per meter, 21W, mounts to a 6060 extruded anodized aluminium profile covered with translucent anti-glare polycarbonate. On/Off touch switch. Fits to the underside of the countertop of overlay panels just above the worksurface.

LED transformer, 24W 1A with 190-250V AC input voltage. 2m long power cable. One transformer supplies power for one overlay panel complete both with LED lighting fitted at its lower end and above the worksurface. Screws to the inner face of the back panel of straight or corner sections.



Z2 RECEPTION DESK WITH OVERLAY PANEL

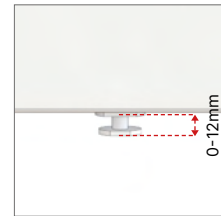
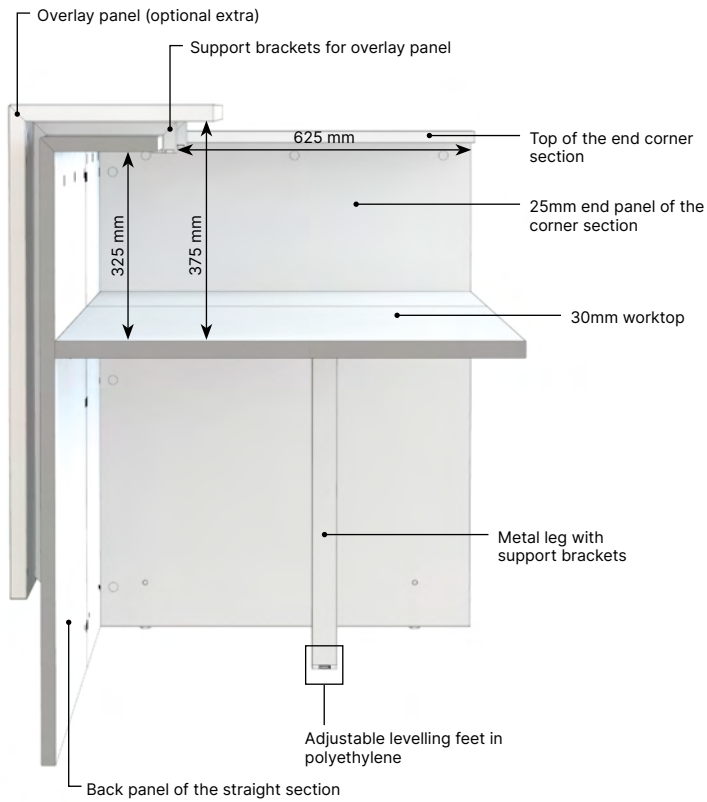

Polyethylene levelling feet, 21x18mm, 0-12mm travel.

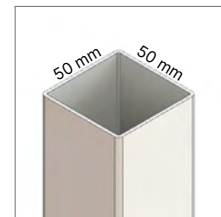

Tubular support legs made of 50x50mm 1.5mm thick steel tube supplied with 3mm steel support plate.

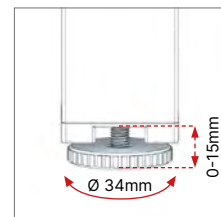

Polyethylene levelling feet, Ø34mm, 0-15mm travel.

Z2 RECEPTION WITH LH DDA COMPLIANT SECTION

(codes for left and right are from the perspective of the receptionist)

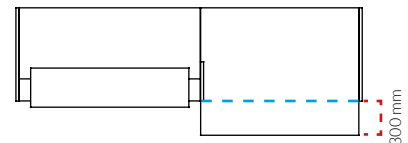
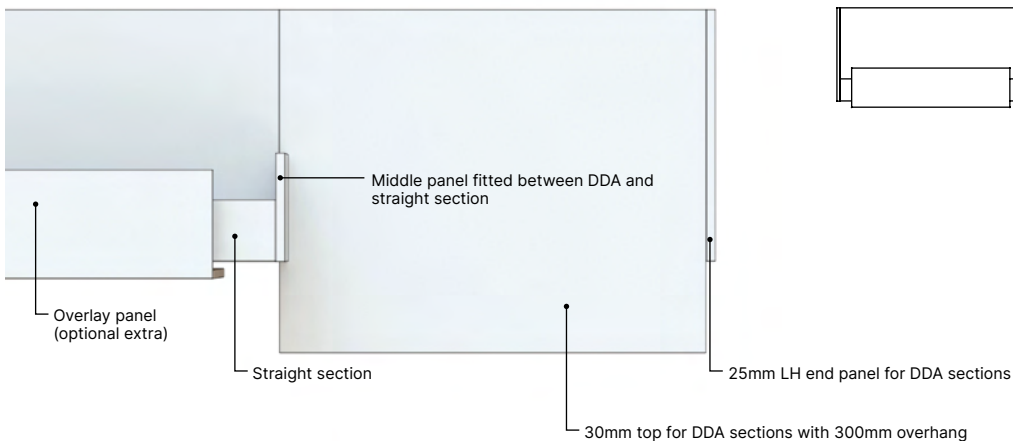

SINGLE PARTS

Straight section

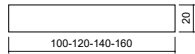

Corner section

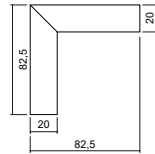

Overlay panel

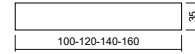

DDA compliant section

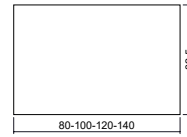

Straight section top

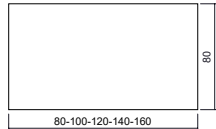

DDA section top

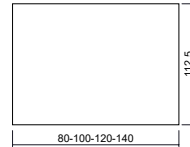

EXAMPLES OF CONFIGURATIONS

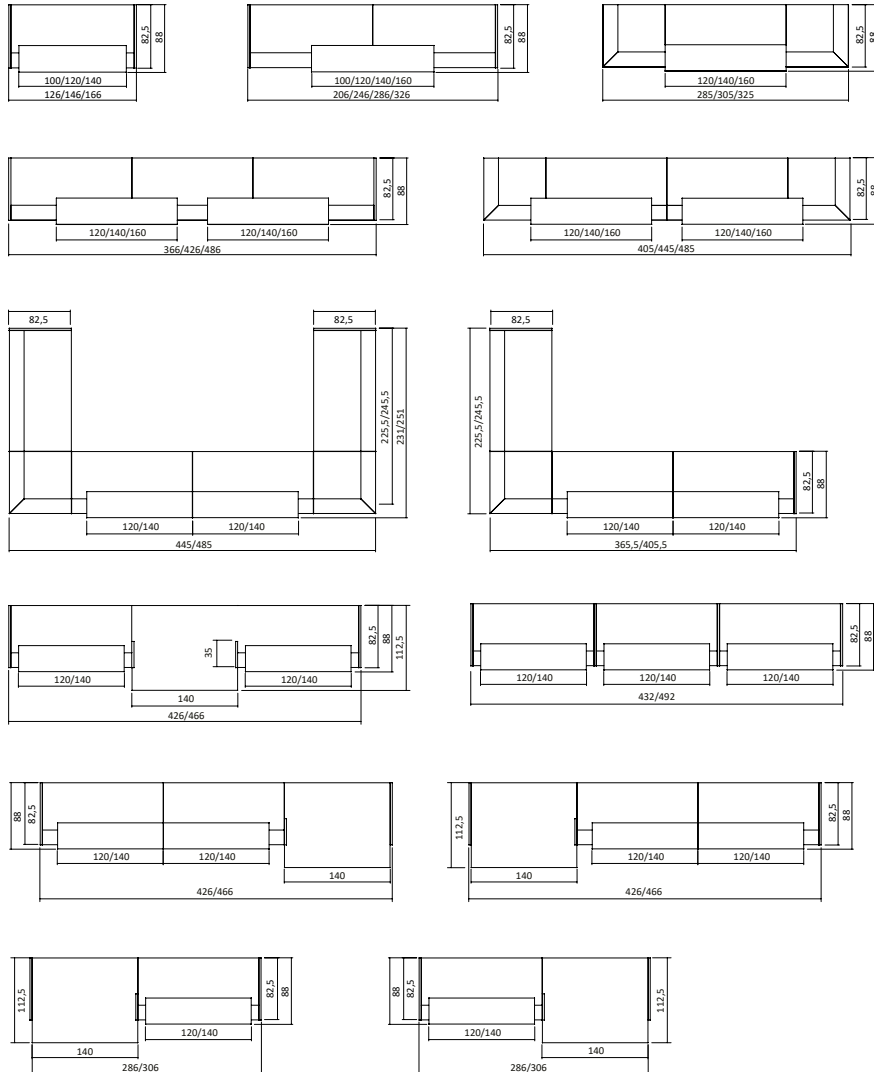

STRAIGHT RECEPTION DESK

- 1) LH end panel
- 2) Straight section
- 3) Worktop
- 4) Support brackets for worktops
- 5) Middle support leg
- 6) RH end panel

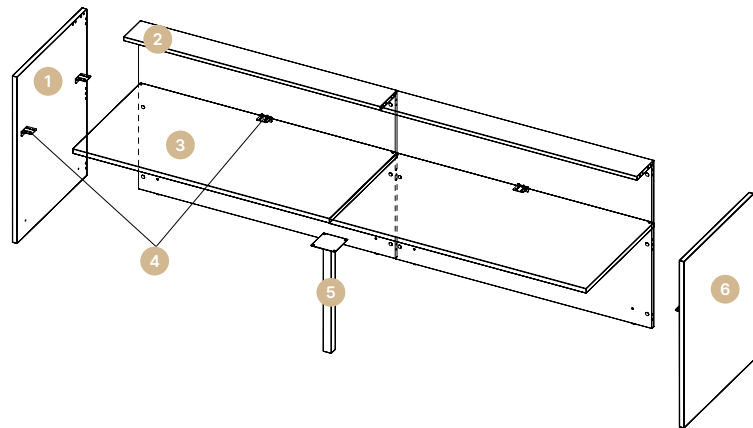

STRAIGHT RECEPTION DESK WITH MIDDLE PANELS BETWEEN WORKSTATIONS

- 1) LH end panel
- 2) Support brackets for worktops
- 3) Middle panels
- 4) RH end panel

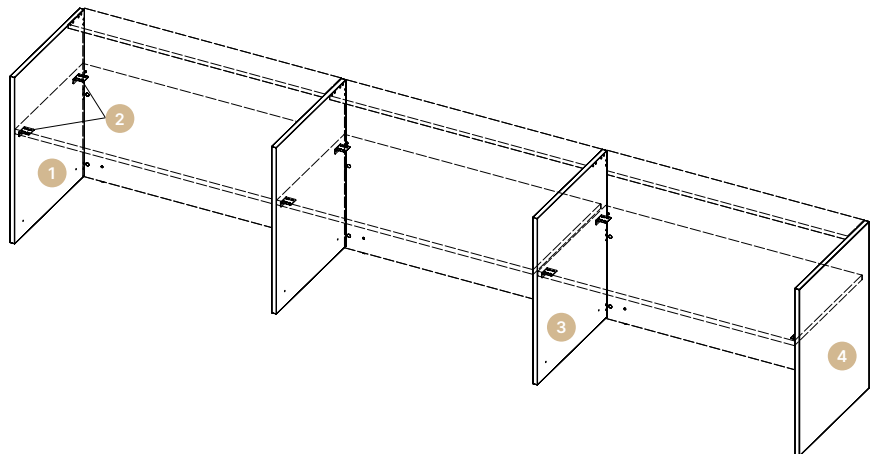

STRAIGHT RECEPTION DESK WITH OVERLAY PANELS

- 1) Overlay panels
- 2) Support brackets for overlay panels

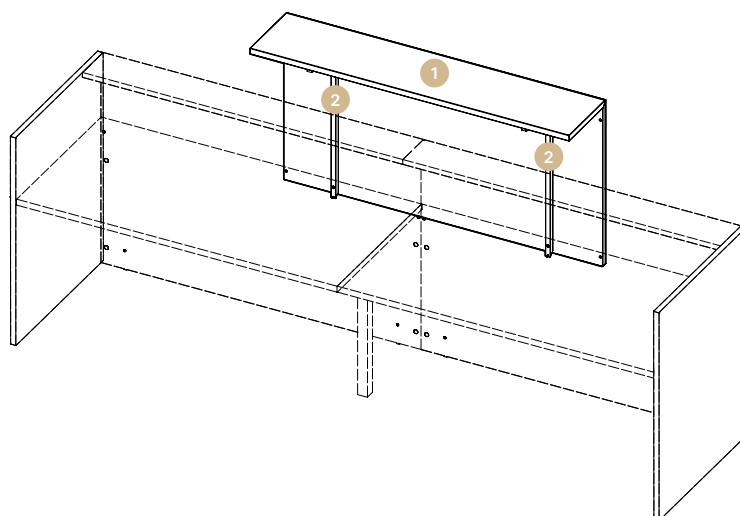
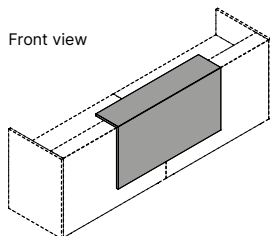

L-SHAPED RECEPTION DESK

- 1) LH end corner section
- 2) Worktop for corner section
- 3) Middle support leg
- 4) Middle corner section

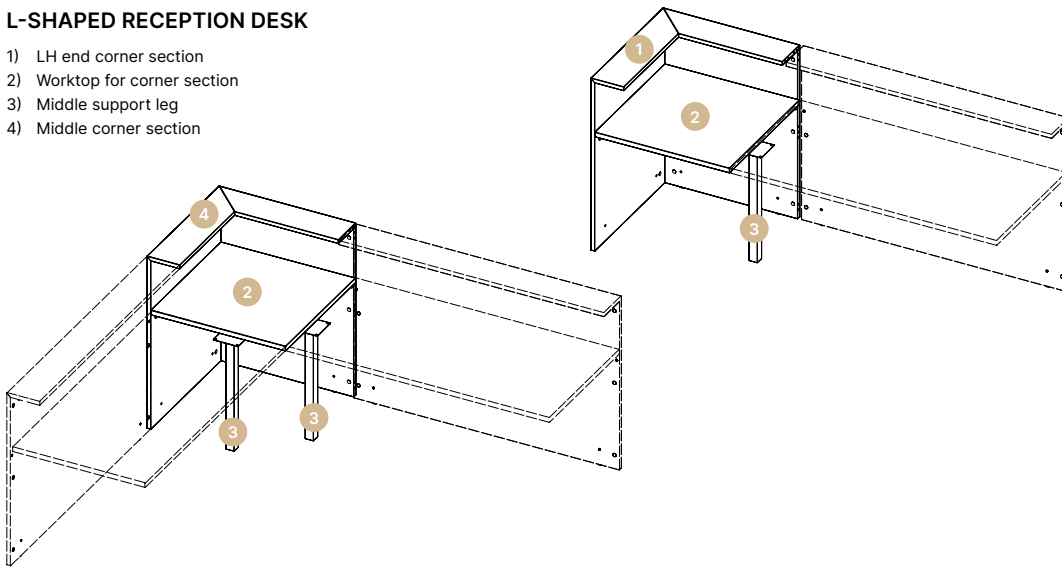

RECEPTION DESKS INCLUDING DDA COMPLIANT SECTIONS

- 1) LH end corner section
- 2) Straight section
- 3) Straight section worktop
- 4) Overlay panel
- 5) Middle panel fitted between DDA and straight section
- 6) DDA section worktop with 300mm overhang
- 7) RH end DDA section
- 8) RH end panel
- 9) Middle support leg
- 10) Middle DDA section

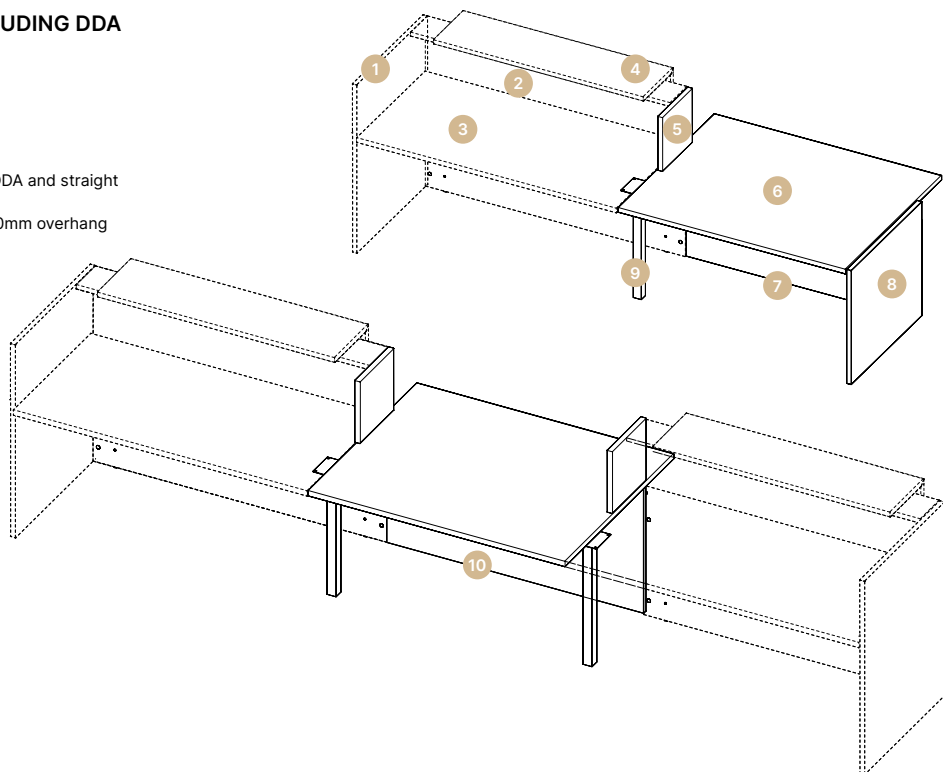



Ø60mm ABS grommet



Aluminium cable flap with open ended cable tray under



PVC cable tray (optional extra)



Translucent Abs cable spine



Peel-and-stick translucent polycarbonate cable riser



LED strip for fitting to the lower end of overlay panels







LED strip for fitting to the underside of countertops above workspace



MATERIALS AND RECYCLABILITY

MFC panels used for the Z2 range are solely manufactured with 100% recycled wood and fully meet requisites of formaldehyde low emissions (CARB Quality Award Formaldehyde CATAS Certificate). Resins used for panels and melamines are free of SVHC substances (to be found in the ECHA list updated as of 12/01/2017)

	POST-CONSUMER RECYCLABLE
 Wood	100%
 Plastic	100%
 Metal	100%
 Mixed	If disposed of in a specialised facilities

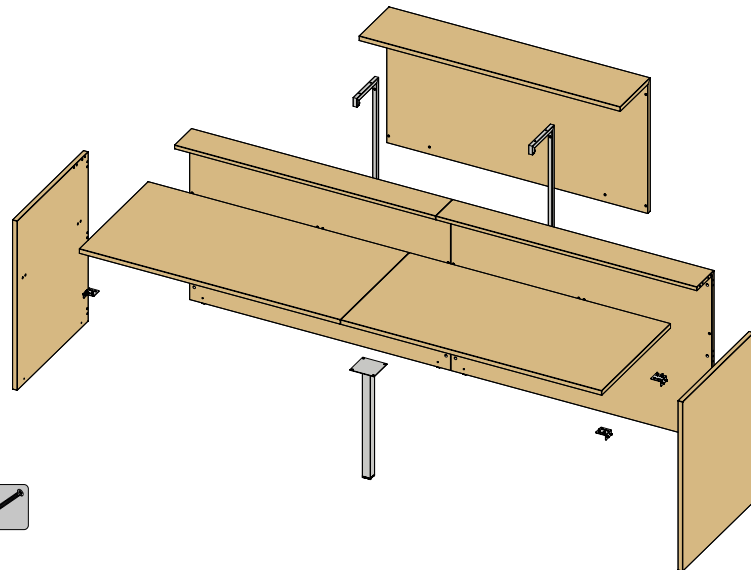

STANDARDS

Z2 has passed the following tests as certified by the **CATAS** Laboratories in San Giovanni al Natisone - Udine, Italy.

- Non domestic tables: safety requirements EN 15372:2016 clause 5.1 - 5.2
- Non domestic tables: information for use EN 15372:2016, clause 6
- Horizontal static load test EN 1730:2012, clause 6.2
- Vertical static load test EN 1730:2012, clause 6.3
- Horizontal fatigue test EN 1730:2012, clause 6.4.2
- Vertical impact test EN 1730:2012, clause 6.6
- Drop test EN 1730:2012, clause 6.9
- Stability under vertical load EN 1730:2012, clause 7.2

STANDARDS FOR MELAMINE FACED CHIPBOARD (MFC)

- UNI EN 15185:2011 - Resistenza all'abrasione
- UNI EN 15186:2012, met.B - Resistenza alla graffiatura (sostituisce norma UNI 9428:1989, ritirata)
- EN 12720:2013 - Resistenza delle superfici ai liquidi freddi

STANDARDS LACQUERED

- UNI EN 15185:2011 - Resistenza all'abrasione
- UNI EN 15186:2012, met.B - Resistenza alla graffiatura (sostituisce norma UNI 9428:1989, ritirata)

STANDARDS LED

- EN 60598-1 - Apparecchi di illuminazione - Prescrizioni generali e prove
- EN 60598-2-4 - Apparecchi di illuminazione - Prescrizioni particolari - Apparecchi di illuminazione mobili di uso generale
- EN 55015:2006 + A1:2007 + A2 :2009 - Limiti e metodi di misura delle caratteristiche di radiodisturbo degli apparecchi di illuminazione elettrici e degli apparecchi analoghi
- EN 61547: 1995 + A1:2000 - Apparecchiature per illuminazione generale - Prescrizioni di immunità EMC
- IEC 62471 - Sicurezza Fotobiologica delle lampade e sistemi di lampade



CERTIFICATIONS

Constantly receptive to market requirements, Quadrifoglio Group pay special attention on quality and safety contents in order to provide high products and services. The Company has reached certifications UNI EN ISO 9001/2015, UNI EN ISO 14001/2015 and UNI EN ISO 45001/2018 to confirm his policy. Our products are certified and ensured by FSC™ and ECOLOGICAL PANEL.

COMPANY WITH
MANAGEMENT SYSTEM
CERTIFIED BY DNV
ISO 9001 - ISO 14001
ISO 45001



GREEN ENERGY

The Company had installed the photovoltaic system with 4.500 solar panels in a 7.350 m² surface that covers almost entirely the factory. The photovoltaic is able to produce 1Mw of a quiet green energy, that does not harm the environment and is waste-free. With his high production capacity the photovoltaic allows us to reduce emissions in the atmosphere of all those polluting substances and to those that contribute to the greenhouse effects. Consequently, such measures make us save every year 180 tonne of petrol oil, 440 tonne of CO₂, 514kg of sulphur dioxide, 448 kg of nitrogen oxide and 23kg of dust.



TRANSPORT

Packaging is reduced in order to decrease volumes. Goods collections are responsibly managed and organised with the aim of optimise transports, reducing atmosphere emissions.